

BME 401 HW1: Solutions

$$1) \quad H(z) = \frac{1 - z^{-1}}{1 + \frac{3}{4}z^{-1}}, \quad x[n] = \left(\frac{1}{3}\right)^n u[n] + u[-n-1].$$

a) Method 1:

$$\text{Using long division } \frac{1 - z^{-1}}{1 + \frac{3}{4}z^{-1}} \left| \frac{1 + \frac{3}{4}z^{-1}}{1} \right., \quad H(z) = 1 + \frac{-\frac{7}{4}z^{-1}}{1 + \frac{3}{4}z^{-1}} = 1 - \frac{7}{4} \frac{z^{-1}}{1 + \frac{3}{4}z^{-1}}$$

As the system is given casual, we expect that the LTI system is a right sided sequence

We know that $\delta[n] \xrightarrow{z} 1$, $a^n u[n] \xrightarrow{z} \frac{1}{1 - az^{-1}}$, $|z| > |a|$ and $x[n-k] \xrightarrow{z} z^{-k} X(z)$ same ROC as $X(z)$.

$$h[n] = \delta[n] - \frac{7}{4} \left(-\frac{3}{4}\right)^{n-1} u[n-1]$$

Method 2:

As the system is given casual, we expect that the LTI system is a right sided sequence

We know that $a^n u[n] \xrightarrow{z} \frac{1}{1 - az^{-1}}$, where $|z| > |a|$ and $x[n-k] \xrightarrow{z} z^{-k} X(z)$ for same ROC as $X(z)$

$$H(z) = \frac{1 - z^{-1}}{1 + \frac{3}{4}z^{-1}} = \frac{1}{1 + \frac{3}{4}z^{-1}} - \frac{z^{-1}}{1 + \frac{3}{4}z^{-1}}, \quad h[n] = \left(-\frac{3}{4}\right)^n u[n] - \left(-\frac{3}{4}\right)^{n-1} u[n-1]$$

b) $x[n] = \left(\frac{1}{3}\right)^n u[n] + u[-n-1]$, We know that $a^n u[n] \xrightarrow{z} \frac{1}{1 - az^{-1}}$, $|z| > |a|$ and $-a^n u[-n-1] \xrightarrow{z} \frac{1}{1 - az^{-1}}$ where $|z| < |a|$.

$$\text{so } X(z) = \frac{1}{1 - \frac{1}{3}z^{-1}} - \frac{1}{1 - z^{-1}} = \frac{1 - z^{-1} - 1 + \frac{1}{3}z^{-1}}{\left(1 - z^{-1}\right)\left(1 - \frac{1}{3}z^{-1}\right)} = \frac{-\frac{2}{3}z^{-1}}{\left(1 - z^{-1}\right)\left(1 - \frac{1}{3}z^{-1}\right)}, \text{ with}$$

$$\text{ROC}(X(z)) = |z| > \frac{1}{3} \cap |z| < 1 = \frac{1}{3} < |z| < 1.$$

$$Y(z) = X(z)H(z) = \left(\frac{-\frac{2}{3}z^{-1}}{\left(1-z^{-1}\right)\left(1-\frac{1}{3}z^{-1}\right)} \right) \left(\frac{1-z^{-1}}{1+\frac{3}{4}z^{-1}} \right) = \frac{-\frac{2}{3}z^{-1}}{\left(1-\frac{1}{3}z^{-1}\right)\left(1+\frac{3}{4}z^{-1}\right)}$$

$$Y(z) = \frac{-\frac{2}{3}z^{-1}}{\left(1-\frac{1}{3}z^{-1}\right)\left(1+\frac{3}{4}z^{-1}\right)} = \frac{A}{1-\frac{1}{3}z^{-1}} + \frac{B}{1+\frac{3}{4}z^{-1}} = \frac{A + A\frac{3}{4}z^{-1} + B - B\frac{1}{3}z^{-1}}{\left(1-\frac{1}{3}z^{-1}\right)\left(1+\frac{3}{4}z^{-1}\right)}$$

$$A + B = 0, \quad \frac{3}{4}A - \frac{1}{3}B = -\frac{2}{3}, \quad A = -\frac{8}{13}, \quad B = \frac{8}{13}.$$

$$Y(z) = \frac{-\frac{2}{3}z^{-1}}{\left(1-\frac{1}{3}z^{-1}\right)\left(1+\frac{3}{4}z^{-1}\right)} = -\frac{8}{13} \frac{1}{1-\frac{1}{3}z^{-1}} + \frac{8}{13} \frac{1}{1+\frac{3}{4}z^{-1}}$$

From convolution property $\text{ROC}(Y(z)) = \text{ROC}(X(z)) \cap \text{ROC}(H(z))$

$$\text{ROC}(X(z)) = \frac{1}{3} < |z| < 1, \quad \text{ROC}(H(z)) = |z| > \frac{3}{4}, \quad \text{ROC}(Y(z)) = \frac{1}{3} < |z| < \frac{3}{4},$$

So first equation is a right sided sequence second one is a left sided sequence.

$$y[n] = -\frac{8}{13} \left(\frac{1}{3}\right)^n u[n] - \frac{8}{13} \left(-\frac{3}{4}\right)^n u[-n-1]$$

c)

We should analyze ROC of H(z), if ROC has unit circle then the system is stable.

$$\text{ROC}(H(z)) = |z| > \frac{3}{4}, \text{ so the system is STABLE.}$$

2)

$$H(z) = \frac{1+z^{-1}}{\left(1-\frac{1}{2}z^{-1}\right)\left(1+\frac{1}{4}z^{-1}\right)} = \frac{A}{1-\frac{1}{2}z^{-1}} + \frac{B}{1+\frac{1}{4}z^{-1}} = \frac{A + A\frac{1}{4}z^{-1} + B - B\frac{1}{2}z^{-1}}{\left(1-\frac{1}{2}z^{-1}\right)\left(1+\frac{1}{4}z^{-1}\right)}$$

$$A+B=1, \quad \frac{1}{4}A - \frac{1}{2}B=1, \quad A=2, \quad B=-1.$$

$$H(z) = \frac{1+z^{-1}}{\left(1-\frac{1}{2}z^{-1}\right)\left(1+\frac{1}{4}z^{-1}\right)} = \frac{2}{1-\frac{1}{2}z^{-1}} - \frac{1}{1+\frac{1}{4}z^{-1}}$$

we need to find ROC

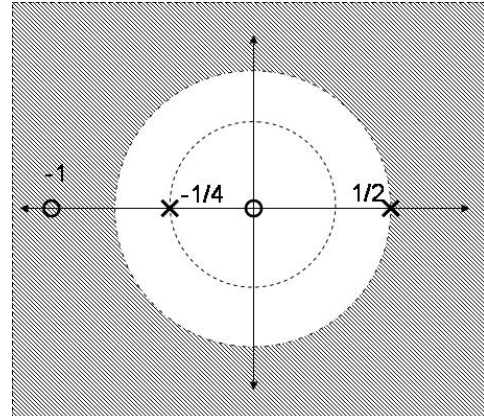

a)

Assume system is Casual then

$$\text{ROC} = |z| > \frac{1}{2} \cap |z| > \frac{1}{4} = |z| > \frac{1}{2}.$$

$$H(z) = \frac{z^2}{z^2} \frac{1+z^{-1}}{\left(1-\frac{1}{2}z^{-1}\right)\left(1+\frac{1}{4}z^{-1}\right)} = \frac{z(z+1)}{\left(z-\frac{1}{2}\right)\left(z+\frac{1}{4}\right)}$$

We have poles at $z = \frac{1}{2}, -\frac{1}{4}$ and zeros at $z = 0, -1$.

$$h[n] = 2\left(\frac{1}{2}\right)^n u[n] - \left(-\frac{1}{4}\right)^n u[n]$$

b)

We should analyze ROC of $H(z)$, if ROC has unit circle than the system is stable.

$$\text{ROC}(H(z)) = |z| > \frac{1}{2}, \text{ so the system is STABLE.}$$

c)

$$y[n] = -\frac{1}{3}\left(-\frac{1}{4}\right)^n u[n] - \frac{4}{3}(2)^n u[-n-1]$$

We know that $a^n u[n] \xleftrightarrow{z} \frac{1}{1-az^{-1}}, |z| > |a|$ and $-a^n u[-n-1] \xleftrightarrow{z} \frac{1}{1-az^{-1}}$ where $|z| < |a|$.

$$\text{so } Y(z) = \frac{-\frac{1}{3}}{1+\frac{1}{4}z^{-1}} + \frac{\frac{4}{3}}{1-2z^{-1}} = \frac{-\frac{1}{3} + \frac{2}{3}z^{-1} + \frac{4}{3} + \frac{1}{3}z^{-1}}{\left(1+\frac{1}{4}z^{-1}\right)\left(1-2z^{-1}\right)} = \frac{1+z^{-1}}{\left(1+\frac{1}{4}z^{-1}\right)\left(1-2z^{-1}\right)}, \text{ with}$$

$$X(z) = \frac{Y(z)}{H(z)} = \frac{1+z^{-1}}{\left(1+\frac{1}{4}z^{-1}\right)\left(1-2z^{-1}\right)} \bigg/ \frac{1+z^{-1}}{\left(1-\frac{1}{2}z^{-1}\right)\left(1+\frac{1}{4}z^{-1}\right)} = \frac{1-\frac{1}{2}z^{-1}}{1-2z^{-1}} = \frac{z-\frac{1}{2}}{z-2}$$

3)

$$x[n] = \left(\frac{1}{3}\right)^n u[n] + (2)^n u[-n-1], \quad y[n] = 5\left(\frac{1}{3}\right)^n u[n] - 5\left(\frac{2}{3}\right)^n u[n].$$

a)

We know that $a^n u[n] \xleftrightarrow{z} \frac{1}{1-az^{-1}}$, $|z| > |a|$ and $-a^n u[-n-1] \xleftrightarrow{z} \frac{1}{1-az^{-1}}$ where $|z| < |a|$.

$$X(z) = \frac{1}{1-\frac{1}{3}z^{-1}} - \frac{1}{1-2z^{-1}} = \frac{1-2z^{-1}-1+\frac{1}{3}z^{-1}}{(1-2z^{-1})\left(1-\frac{1}{3}z^{-1}\right)} = \frac{-\frac{5}{3}z^{-1}}{(1-2z^{-1})\left(1-\frac{1}{3}z^{-1}\right)}$$

$$\text{ROC}(X(z)) = |z| > \frac{1}{3} \cap |z| < 2 = \frac{1}{3} < |z| < 2.$$

$$Y(z) = \frac{5}{1-\frac{1}{3}z^{-1}} - \frac{5}{1-\frac{2}{3}z^{-1}} = \frac{5-\frac{10}{3}z^{-1}-5+\frac{5}{3}z^{-1}}{\left(1-\frac{2}{3}z^{-1}\right)\left(1-\frac{1}{3}z^{-1}\right)} = \frac{-\frac{5}{3}z^{-1}}{\left(1-\frac{2}{3}z^{-1}\right)\left(1-\frac{1}{3}z^{-1}\right)}$$

$$\text{ROC}(Y(z)) = |z| > \frac{1}{3} \cap |z| > \frac{2}{3} = |z| > \frac{2}{3}.$$

$$H(z) = \frac{Y(z)}{X(z)} = \frac{-\frac{5}{3}z^{-1}}{\left(1-\frac{2}{3}z^{-1}\right)\left(1-\frac{1}{3}z^{-1}\right)} \bigg/ \frac{-\frac{5}{3}z^{-1}}{(1-2z^{-1})\left(1-\frac{1}{3}z^{-1}\right)} = \frac{1-2z^{-1}}{1-\frac{2}{3}z^{-1}} = \frac{z-2}{z-\frac{2}{3}}$$

We should analyze $Y(z)$ and $X(z)$ to obtain the ROC of $H(z)$ as $\text{ROC}(Y(z)) = |z| > \frac{2}{3}$.

$$\text{ROC}(X(z)) = \frac{1}{3} < |z| < 2. \text{ Then } \text{ROC}(H(z)) = |z| > \frac{2}{3}.$$

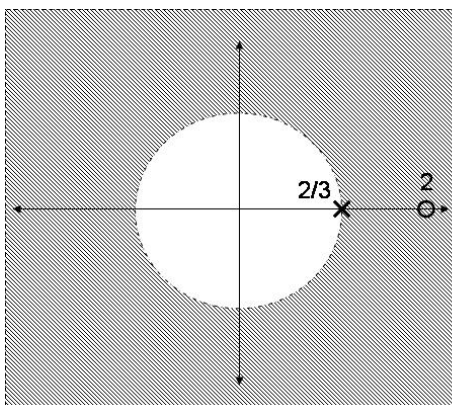

b)

$$H(z) = \frac{1-2z^{-1}}{1-\frac{2}{3}z^{-1}} \quad \text{Using long division} \quad \begin{array}{r} 1-2z^{-1} \bigg| 1-\frac{2}{3}z^{-1} \\ \underline{1-\frac{2}{3}z^{-1}} \\ -\frac{4}{3}z^{-1} \end{array}, \quad H(z) = 1 - \frac{4}{3} \frac{z^{-1}}{1-\frac{2}{3}z^{-1}}$$

We know that $\text{ROC}(H(z)) = |z| > \frac{2}{3}$ so $h[n] = \delta[n] - \frac{4}{3} \left(\frac{2}{3}\right)^n u[n]$.

c)

$$H(z) = \frac{Y(z)}{X(z)} = \frac{1-2z^{-1}}{1-\frac{2}{3}z^{-1}}, \quad Y(z) \left(1-\frac{2}{3}z^{-1}\right) = X(z)(1-2z^{-1})$$

so $y[n] - \frac{2}{3}y[n-1] = x[n] - 2x[n-1]$.

d)

If the sequence of $h[n]$ is right sided the ROC becomes outer of a circle so we know that $\text{ROC}(H(z)) = |z| > \frac{2}{3}$, so the system is CASUAL.

If ROC of $H(z)$ has unit circle than the system is stable.

we know that $\text{ROC}(H(z)) = |z| > \frac{2}{3}$. so the system is STABLE.

$$4) \quad y[n] - \frac{5}{2}y[n-1] + y[n-2] = x[n] - x[n-1]$$

$$Y(z) - \frac{5}{2}z^{-1}Y(z) + z^{-2}Y(z) = X(z) - z^{-1}X(z)$$

$$Y(z) \left(1 - \frac{5}{2}z^{-1} + z^{-2} \right) = X(z) (1 - z^{-1}), \quad \frac{Y(z)}{X(z)} = H(z) = \frac{1 - z^{-1}}{1 - \frac{5}{2}z^{-1} + z^{-2}}$$

$$\begin{array}{cc} 1 & -1/2z^{-1} \\ 1 & -2z^{-1} \end{array}$$

$$H(z) = \frac{1 - z^{-1}}{1 - \frac{5}{2}z^{-1} + z^{-2}} = \frac{1 - z^{-1}}{\left(1 - \frac{1}{2}z^{-1}\right)(1 - 2z^{-1})} = \frac{A}{1 - \frac{1}{2}z^{-1}} + \frac{B}{1 - 2z^{-1}}$$

$$H(z) = \frac{1 - z^{-1}}{\left(1 - \frac{1}{2}z^{-1}\right)(1 - 2z^{-1})} = \frac{A}{1 - \frac{1}{2}z^{-1}} + \frac{B}{1 - 2z^{-1}} = \frac{A - 2Az^{-1} + B - \frac{1}{2}Bz^{-1}}{\left(1 - \frac{1}{2}z^{-1}\right)(1 - 2z^{-1})}$$

$$A + B = 1 \quad -2A - \frac{1}{2}B = -1 \quad A = \frac{1}{3} \quad B = \frac{2}{3}$$

$$H(z) = \frac{1}{3} \frac{1}{\left(1 - \frac{1}{2}z^{-1}\right)} + \frac{2}{3} \frac{1}{(1 - 2z^{-1})}$$

There are 3 possible ROC let say R1, R2, and R3 for the sequence which are:

$$R1 = |z| > 2, \quad R2 = \frac{1}{2} < |z| < 2, \quad R3 = |z| < \frac{1}{2}$$

$$\text{For R1: } h[n] = \frac{1}{3} \left(\frac{1}{2}\right)^n u[n] + \frac{2}{3} (2)^n u[n] \quad \text{so } h[0] = \frac{1}{3} \left(\frac{1}{2}\right)^0 u[0] + \frac{2}{3} (2)^0 u[0] = 1$$

$$\text{For R2: } h[n] = \frac{1}{3} \left(\frac{1}{2}\right)^n u[n] - \frac{2}{3} (2)^n u[-n-1] \quad \text{so } h[0] = \frac{1}{3} \left(\frac{1}{2}\right)^0 u[0] - \frac{2}{3} (2)^0 u[0-1] = \frac{1}{3}$$

$$\text{For R3: } h[n] = -\frac{1}{3} \left(\frac{1}{2}\right)^n u[-n-1] - \frac{2}{3} (2)^n u[-n-1] \quad \text{so } h[0] = -\frac{1}{3} \left(\frac{1}{2}\right)^0 u[0-1] - \frac{2}{3} (2)^0 u[0-1] = 0$$

5)

$$X(z) = \frac{1}{\left(1 + \frac{1}{2}z^{-1}\right)^2 (1 - 2z^{-1})(1 - 3z^{-1})} = \frac{A}{1 + \frac{1}{2}z^{-1}} + \frac{B}{\left(1 + \frac{1}{2}z^{-1}\right)^2} + \frac{C}{1 - 2z^{-1}} + \frac{D}{1 - 3z^{-1}}$$

$$X(z) = \frac{A}{1 + \frac{1}{2}z^{-1}} + \frac{B}{\left(1 + \frac{1}{2}z^{-1}\right)^2} + \frac{C}{1 - 2z^{-1}} + \frac{D}{1 - 3z^{-1}} \quad (\text{eq. 1})$$

$$X(z) = \frac{A}{1 + \frac{1}{2}z^{-1}} + \frac{B}{\left(1 + \frac{1}{2}z^{-1}\right)^2} + \frac{C}{1 - 2z^{-1}} + \frac{D}{1 - 3z^{-1}}$$

$$\frac{\left(1 + \frac{1}{2}z^{-1}\right)(1 - 2z^{-1})(1 - 3z^{-1})}{(1 + \dots)} \quad \frac{(1 - 2z^{-1})(1 - 3z^{-1})}{(1 + \dots)} \quad \frac{\left(1 + \frac{1}{2}z^{-1}\right)^2(1 - 3z^{-1})}{(1 + \dots)} \quad \frac{\left(1 + \frac{1}{2}z^{-1}\right)^2(1 - 2z^{-1})}{(1 + \dots)}$$

so we have $A + B + C + D = 1$ after we solve B, C and D we may find A using the equation.

For solving B lets multiply both sides of eq.1 by $\left(1 + \frac{1}{2}z^{-1}\right)^2$ we have

$$\left(1 + \frac{1}{2}z^{-1}\right)^2 \frac{1}{\left(1 + \frac{1}{2}z^{-1}\right)^2 (1 - 2z^{-1})(1 - 3z^{-1})} = \left(1 + \frac{1}{2}z^{-1}\right)^2 \frac{A}{1 + \frac{1}{2}z^{-1}} + \left(1 + \frac{1}{2}z^{-1}\right)^2 \frac{B}{\left(1 + \frac{1}{2}z^{-1}\right)^2} + \left(1 + \frac{1}{2}z^{-1}\right)^2 \frac{C}{1 - 2z^{-1}} + \left(1 + \frac{1}{2}z^{-1}\right)^2 \frac{D}{1 - 3z^{-1}}$$

$$\frac{1}{(1 - 2z^{-1})(1 - 3z^{-1})} = \left(1 + \frac{1}{2}z^{-1}\right)A + B + \left(1 + \frac{1}{2}z^{-1}\right)^2 \frac{C}{1 - 2z^{-1}} + \left(1 + \frac{1}{2}z^{-1}\right)^2 \frac{D}{1 - 3z^{-1}}$$

for $z^{-1} = -2$ we have $\left(1 + \frac{1}{2}(-2)\right)^2 = 0$ then

$$\frac{1}{(1 - 2(-2))(1 - 3(-2))} = \left(1 + \frac{1}{2}(-2)\right)A + B + \left(1 + \frac{1}{2}(-2)\right)^2 \frac{C}{1 - 2z^{-1}} + \left(1 + \frac{1}{2}(-2)\right)^2 \frac{D}{1 - 3z^{-1}}$$

$$\frac{1}{(1 - 2(-2))(1 - 3(-2))} = B = \frac{1}{35}$$

For solving C lets multiply both sides of eq.1 by $(1-2z^{-1})$ we have

$$(1-2z^{-1}) \frac{1}{\left(1+\frac{1}{2}z^{-1}\right)^2 (1-2z^{-1})(1-3z^{-1})} =$$

$$(1-2z^{-1}) \frac{A}{1+\frac{1}{2}z^{-1}} + (1-2z^{-1}) \frac{B}{\left(1+\frac{1}{2}z^{-1}\right)^2} + (1-2z^{-1}) \frac{C}{1-2z^{-1}} + (1-2z^{-1}) \frac{D}{1-3z^{-1}}$$

$$\frac{1}{\left(1+\frac{1}{2}z^{-1}\right)^2 (1-3z^{-1})} = (1-2z^{-1}) \frac{A}{1+\frac{1}{2}z^{-1}} + (1-2z^{-1}) \frac{B}{\left(1+\frac{1}{2}z^{-1}\right)^2} + C + (1-2z^{-1}) \frac{D}{1-3z^{-1}}$$

for $z^{-1} = \frac{1}{2}$ we have $(1-2z^{-1}) = 0$ then

$$\frac{1}{\left(1+\frac{1}{2}\left(\frac{1}{2}\right)\right)^2 \left(1-3\left(\frac{1}{2}\right)\right)} = \left(1-2\left(\frac{1}{2}\right)\right) \frac{A}{1+\frac{1}{2}\left(\frac{1}{2}\right)} + \left(1-2\left(\frac{1}{2}\right)\right) \frac{B}{\left(1+\frac{1}{2}\left(\frac{1}{2}\right)\right)^2} + C + \left(1-2\left(\frac{1}{2}\right)\right) \frac{D}{1-3\left(\frac{1}{2}\right)}$$

$$\frac{1}{\left(1+\frac{1}{2}\left(\frac{1}{2}\right)\right)^2 \left(1-3\left(\frac{1}{2}\right)\right)} = C = \frac{1}{\left(\frac{5}{4}\right)^2 \left(-\frac{1}{2}\right)} = \frac{1}{-\frac{25}{32}} = -\frac{32}{25}$$

For solving D lets multiply both sides of eq.1 by $(1-3z^{-1})$ we have

$$(1-3z^{-1}) \frac{1}{\left(1+\frac{1}{2}z^{-1}\right)^2 (1-2z^{-1})(1-3z^{-1})} =$$

$$(1-3z^{-1}) \frac{A}{1+\frac{1}{2}z^{-1}} + (1-3z^{-1}) \frac{B}{\left(1+\frac{1}{2}z^{-1}\right)^2} + (1-3z^{-1}) \frac{C}{1-2z^{-1}} + (1-3z^{-1}) \frac{D}{1-3z^{-1}}$$

$$\frac{1}{\left(1+\frac{1}{2}z^{-1}\right)^2 (1-2z^{-1})} = (1-3z^{-1}) \frac{A}{1+\frac{1}{2}z^{-1}} + (1-3z^{-1}) \frac{B}{\left(1+\frac{1}{2}z^{-1}\right)^2} + (1-3z^{-1}) \frac{C}{1-2z^{-1}} + D$$

for $z^{-1} = \frac{1}{3}$ we have $(1-3z^{-1}) = 0$ then

$$\frac{1}{\left(1+\frac{1}{2}\left(\frac{1}{3}\right)\right)^2 \left(1-2\left(\frac{1}{3}\right)\right)} = \left(1-3\left(\frac{1}{3}\right)\right) \frac{A}{1+\frac{1}{2}\left(\frac{1}{3}\right)} + \left(1-3\left(\frac{1}{3}\right)\right) \frac{B}{\left(1+\frac{1}{2}\left(\frac{1}{3}\right)\right)^2} + \left(1-3\left(\frac{1}{3}\right)\right) \frac{C}{1-2\left(\frac{1}{3}\right)} + D$$

$$\frac{1}{\left(1+\frac{1}{2}\left(\frac{1}{3}\right)\right)^2 \left(1-2\left(\frac{1}{3}\right)\right)} = D = \frac{1}{\left(\frac{7}{6}\right)^2 \left(\frac{1}{3}\right)} = \frac{1}{\frac{49}{108}} = \frac{108}{49}$$

we know that $A + B + C + D = 1$ so $A + \frac{1}{35} - \frac{32}{25} + \frac{108}{49} = 1$ so

$$A + \frac{1}{7 \cdot 5} - \frac{32}{5 \cdot 5} + \frac{108}{7 \cdot 7} = 1, \quad A = 1 - \frac{1 \cdot 5 \cdot 7}{7 \cdot 7 \cdot 5 \cdot 5} + \frac{32 \cdot 7 \cdot 7}{7 \cdot 7 \cdot 5 \cdot 5} - \frac{108 \cdot 5 \cdot 5}{7 \cdot 7 \cdot 5 \cdot 5}$$

$$A = 1 + \frac{-1 \cdot 5 \cdot 7 + 32 \cdot 7 \cdot 7 - 108 \cdot 5 \cdot 5}{7 \cdot 7 \cdot 5 \cdot 5}, \quad A = 1 + \frac{-35 + 1568 - 2700}{1225} = 1 - \frac{1167}{1225} = \frac{58}{1225}$$

$$X(z) = \frac{A}{1 + \frac{1}{2}z^{-1}} + \frac{B}{\left(1 + \frac{1}{2}z^{-1}\right)^2} + \frac{C}{1 - 2z^{-1}} + \frac{D}{1 - 3z^{-1}}$$

$$X(z) = \frac{\frac{58}{1225}}{1 + \frac{1}{2}z^{-1}} + \frac{\frac{1}{35}}{\left(1 + \frac{1}{2}z^{-1}\right)^2} + \frac{-\frac{32}{25}}{1 - 2z^{-1}} + \frac{\frac{108}{49}}{1 - 3z^{-1}}$$

we know that $x[n]$ is stable so ROC must have the unit circle so we have $\text{ROC} = \frac{1}{2} < |z| < 2$, the first and second equation are right sided third and fourth are left sided and we should compute second equation differentiation property,

if $s[n] \xleftrightarrow{z} S(z)$ with $\text{ROC} = R$ then $ns[n] \xleftrightarrow{z} -z \frac{dS(z)}{dz}$ with $\text{ROC} = R$

so $s[n] = \left(-\frac{1}{2}\right)^n u[n] \xleftrightarrow{z} \frac{1}{1 + \frac{1}{2}z^{-1}}$ with $\text{ROC} = R$ and $s[n]$ right sided

then $ns[n] = n \left(-\frac{1}{2}\right)^n u[n] \xleftrightarrow{z} -z \frac{d}{dz} \left(\frac{1}{1 + \frac{1}{2}z^{-1}} \right) = -z \frac{\frac{1}{2}z^{-2}}{\left(1 + \frac{1}{2}z^{-1}\right)^2} = -\frac{1}{2} \frac{z^{-1}}{\left(1 + \frac{1}{2}z^{-1}\right)^2}$ with $\text{ROC} = R$

and from time shifting property we have

if $g[n] \xleftrightarrow{z} G(z)$ with $\text{ROC} = R$ then $g[n-k] \xleftrightarrow{z} z^{-k} G(z)$ with $\text{ROC} = R$

$g[n] = -2 \cdot n \cdot s[n] = -2 \cdot n \left(-\frac{1}{2}\right)^n \cdot u[n] \xleftrightarrow{z} \frac{z^{-1}}{\left(1 + \frac{1}{2}z^{-1}\right)^2}$ for $k = -1$ we have

$g[n+1] = -2(n+1)s[n+1] = -2(n+1) \left(-\frac{1}{2}\right)^{n+1} \cdot u[n+1] \xleftrightarrow{z} z \frac{z^{-1}}{\left(1 + \frac{1}{2}z^{-1}\right)^2} = \frac{1}{\left(1 + \frac{1}{2}z^{-1}\right)^2}$

then $x[n]$ would be

$$x[n] = \frac{58}{1125} \left(-\frac{1}{2}\right)^n u[n] - \frac{2}{35} (n+1) \left(-\frac{1}{2}\right)^{n+1} \cdot u[n+1] + \frac{32}{25} (2)^n u[-n-1] - \frac{108}{48} (3)^n u[-n-1]$$

6)

$$X(z) = \frac{3z^{-3}}{\left(1 - \frac{1}{4}z^{-1}\right)^2} \quad \text{and } x[n] \text{ is given left sided}$$

using differentiation property,

$$\text{if } s[n] \xleftrightarrow{z} S(z) \quad \text{with ROC=R} \quad \text{then} \quad ns[n] \xleftrightarrow{z} -z \frac{dS(z)}{dz} \quad \text{with ROC =R}$$

$$\text{so } s[n] = -\left(\frac{1}{4}\right)^n u[-n-1] \xleftrightarrow{z} \frac{1}{1 - \frac{1}{4}z^{-1}} \quad \text{with ROC=R and } s[n] \text{ left sided}$$

then

$$ns[n] = -n\left(\frac{1}{4}\right)^n u[-n-1] \xleftrightarrow{z} -z \frac{d}{dz} \left(\frac{1}{1 - \frac{1}{4}z^{-1}} \right) = -z \frac{-\frac{1}{4}z^{-2}}{\left(1 - \frac{1}{4}z^{-1}\right)^2} = \frac{1}{4} \frac{z^{-1}}{\left(1 - \frac{1}{4}z^{-1}\right)^2} \quad \text{with}$$

ROC=R

and from time shifting property we have

$$\text{if } g[n] \xleftrightarrow{z} G(z) \quad \text{with ROC=R} \quad \text{then} \quad g[n-k] \xleftrightarrow{z} z^{-k}G(z) \quad \text{with ROC =R}$$

$$g[n] = -4 \cdot n \cdot s[n] = -4 \cdot n \left(\frac{1}{4}\right)^n u[-n-1] \xleftrightarrow{z} \frac{z^{-1}}{\left(1 - \frac{1}{4}z^{-1}\right)^2} \quad \text{for } k = 2 \text{ we have}$$

$$g[n-2] = -4(n-2)s[n-2] = -4(n-2)\left(\frac{1}{4}\right)^{n-2} u[-(n-2)-1] \xleftrightarrow{z} z^{-2} \frac{z^{-1}}{\left(1 - \frac{1}{4}z^{-1}\right)^2} = \frac{z^{-3}}{\left(1 - \frac{1}{4}z^{-1}\right)^2}$$

$$3g[n-2] = -3 \cdot 4(n-2)s[n-2] = -3 \cdot 4(n-2)\left(\frac{1}{4}\right)^{n-2} u[-n+1] \xleftrightarrow{z} \frac{3z^{-3}}{\left(1 - \frac{1}{4}z^{-1}\right)^2}$$

then $x[n]$ would be

$$x[n] = -12(n-2)\left(\frac{1}{4}\right)^{n-2} u[-n+1] = -12\left(\frac{1}{4}\right)^{-2} (n-2)\left(\frac{1}{4}\right)^n u[-n+1] = -192 \cdot (n-2)\left(\frac{1}{4}\right)^n u[-n+1]$$

$$x[n] = -192 \cdot (n-2)\left(\frac{1}{4}\right)^n u[-n+1]$$

7)

$$X(z) = \frac{1}{1 - \frac{1}{8}z^{-3}} \quad \text{and } x[n] \text{ is given right sided}$$

Method 1:

using time expansion property

$$\text{if } s[n] = \left(\frac{1}{8}\right)^n u[n] \xleftrightarrow{z} \frac{1}{1 - \frac{1}{8}z^{-1}}$$

$$\text{then } s\left[\frac{n}{k}\right] = \left(\frac{1}{8}\right)^{\frac{n}{k}} u\left[\frac{n}{k}\right] \xleftrightarrow{z} \frac{1}{1 - \frac{1}{8}z^{-k}} \quad \text{where } s\left[\frac{n}{k}\right] = 0 \text{ for } n \text{ is not a multiple of } k$$

$$\text{and } s\left[\frac{n}{k}\right] = s\left[\frac{n}{k}\right] \text{ for } n \text{ is a multiple of } k$$

$$\text{then } k=3 \text{ we have } s\left[\frac{n}{3}\right] = \left(\frac{1}{8}\right)^{\frac{n}{3}} u\left[\frac{n}{3}\right] \xleftrightarrow{z} \frac{1}{1 - \frac{1}{8}z^{-3}} \text{ so } x[n] \text{ becomes}$$

$$x[n] = \left(\frac{1}{2}\right)^n u\left[\frac{n}{3}\right] \quad \text{where if } n \text{ is not a multiple of } 3 \text{ } x[n]=0, \text{ else } x[n] \text{ is has value which can be calculated.}$$

Method 2:

$$X(z) = \frac{1}{1 - \frac{1}{8}z^{-3}} = \frac{1}{1 - \left(\frac{1}{2}z^{-1}\right)^3},$$

Using the definition of z transform let:

$$X(z) = \frac{1}{1 - \frac{1}{8}z^{-3}} = \frac{1}{1 - \left(\frac{1}{2}z^{-1}\right)^3} = \sum_{n=0}^{\infty} \left(\frac{1}{2}z^{-1}\right)^{3n} = \sum_{n=-\infty}^{\infty} \left(\frac{1}{2}\right)^{3n} u[n] z^{-3n} \text{ for } m=3n \text{ we have}$$

$$X(z) = \sum_{m=-\infty}^{\infty} \left(\frac{1}{2}\right)^m u\left[\frac{m}{3}\right] z^{-m} \quad \text{for } m=n \quad X(z) = \sum_{n=-\infty}^{\infty} \left(\frac{1}{2}\right)^n u\left[\frac{n}{3}\right] z^{-n} = \sum_{n=-\infty}^{\infty} x[n] z^{-n}$$

$$\text{so } x[n] = \left(\frac{1}{2}\right)^n u\left[\frac{n}{3}\right] \quad \text{where if } n \text{ is not a multiple of } 3 \text{ } x[n]=0, \text{ else } x[n] \text{ is has value which can be calculated.}$$

8)

We have total 3 poles 2 are at: $z = ae^{jw}, be^{j\theta}$, we should find a, w, b, θ

$$x + jy = \left(\sqrt{x^2 + y^2}\right) e^{j\arctan\left(\frac{y}{x}\right)}$$

$$z_1 = \frac{1}{2} + j\frac{1}{2}, \quad w = \arctan\left(\frac{\frac{1}{2}}{\frac{1}{2}}\right) = \frac{\pi}{4}, \quad a = \sqrt{\left(\frac{1}{2}\right)^2 + \left(\frac{1}{2}\right)^2} = \frac{\sqrt{2}}{2}$$

$$z_{2_1} = \frac{1}{2} - j\frac{1}{2}, \quad \theta = \arctan\left(\frac{-\frac{1}{2}}{\frac{1}{2}}\right) = -\frac{\pi}{4}, \quad b = \sqrt{\left(\frac{1}{2}\right)^2 + \left(-\frac{1}{2}\right)^2} = \frac{\sqrt{2}}{2}$$

so we have poles at: $z = \frac{3}{4}, \frac{\sqrt{2}}{2}e^{-j\frac{\pi}{4}}, \frac{\sqrt{2}}{2}e^{j\frac{\pi}{4}}$

we have zero at: $z = 0$

$$\begin{aligned} \text{so } X(z) &= \frac{z}{\left(z + \frac{3}{4}\right)\left(z - \frac{\sqrt{2}}{2}e^{-j\frac{\pi}{4}}\right)\left(z - \frac{\sqrt{2}}{2}e^{j\frac{\pi}{4}}\right)} = \frac{z^{-2}}{\left(1 + \frac{3}{4}z^{-1}\right)\left(1 - \frac{\sqrt{2}}{2}e^{-j\frac{\pi}{4}}z^{-1}\right)\left(1 - \frac{\sqrt{2}}{2}e^{j\frac{\pi}{4}}z^{-1}\right)} \\ &\left(1 - \frac{\sqrt{2}}{2}e^{-j\frac{\pi}{4}}z^{-1}\right)\left(1 - \frac{\sqrt{2}}{2}e^{j\frac{\pi}{4}}z^{-1}\right) = 1 - \left(\frac{\sqrt{2}}{2}e^{j\frac{\pi}{4}} + \frac{\sqrt{2}}{2}e^{-j\frac{\pi}{4}}\right) + \frac{1}{2}z^{-2} = 1 - 2 \cdot \frac{\sqrt{2}}{2} \cdot \cos\frac{\pi}{4} + \left(\frac{\sqrt{2}}{2}\right)^2 z^{-2} \\ 1 - 2 \cdot \frac{\sqrt{2}}{2} \cdot \cos\frac{\pi}{4} + \left(\frac{\sqrt{2}}{2}\right)^2 z^{-2} &= 1 - z^{-1} + \frac{1}{2}z^{-2} \end{aligned}$$

$$X(z) = \frac{z^{-2}}{\left(1 + \frac{3}{4}z^{-1}\right)\left(1 - z^{-1} + \frac{1}{2}z^{-2}\right)}$$

$$X(z) = \frac{z^{-2}}{\left(1 + \frac{3}{4}z^{-1}\right)\left(1 - z^{-1} + \frac{1}{2}z^{-2}\right)} = \frac{A}{1 + \frac{3}{4}z^{-1}} + \frac{B + Cz^{-1}}{1 - 2 \cdot \frac{\sqrt{2}}{2} \cdot \cos\frac{\pi}{4}z^{-1} + \left(\frac{\sqrt{2}}{2}\right)^2 z^{-2}}$$

$$A + B = 0, \quad A = -B$$

$$-2 \cdot \frac{\sqrt{2}}{2} \cdot \cos\frac{\pi}{4}A + \frac{3}{4}B + C = 0, \quad -A + \frac{3}{4}B + C = 0, \quad -A - \frac{3}{4}A + C = -\frac{7}{4}A + C = 0,$$

$$A = \frac{4}{7}C, \quad \left(\frac{\sqrt{2}}{2}\right)^2 A + \frac{3}{4}C = 1, \quad \frac{1}{2}A + \frac{3}{4}C = 1, \quad \frac{2}{7}C + \frac{3}{4}C = \frac{29}{28}C = 1$$

$$C = \frac{28}{29}, \quad A = \frac{16}{29}, \quad B = -\frac{16}{29}$$

$$X(z) = \frac{A}{1 + \frac{3}{4}z^{-1}} + \frac{B + Cz^{-1}}{1 - 2 \cdot \frac{\sqrt{2}}{2} \cdot \cos \frac{\pi}{4} z^{-1} + \left(\frac{\sqrt{2}}{2}\right)^2 z^{-2}} = \frac{16}{29} \frac{1}{1 + \frac{3}{4}z^{-1}} - \frac{16}{29} \frac{1 - \frac{7}{4}z^{-1}}{1 - 2 \cdot \frac{\sqrt{2}}{2} \cdot \cos \frac{\pi}{4} z^{-1} + \left(\frac{\sqrt{2}}{2}\right)^2 z^{-2}}$$

$$X(z) = \frac{16}{29} \frac{1}{1 + \frac{3}{4}z^{-1}} - \frac{16}{29} \frac{1 - \frac{1}{2}z^{-1} - \frac{5}{4}z^{-1}}{1 - 2 \cdot \frac{\sqrt{2}}{2} \cdot \cos \frac{\pi}{4} z^{-1} + \left(\frac{\sqrt{2}}{2}\right)^2 z^{-2}}$$

$$X(z) = \frac{16}{29} \frac{1}{1 + \frac{3}{4}z^{-1}} - \frac{16}{29} \frac{1 - \frac{1}{2}z^{-1}}{1 - 2 \cdot \frac{\sqrt{2}}{2} \cdot \cos \frac{\pi}{4} z^{-1} + \left(\frac{\sqrt{2}}{2}\right)^2 z^{-2}} - \frac{16}{29} \frac{-\frac{5}{4}z^{-1}}{1 - 2 \cdot \frac{\sqrt{2}}{2} \cdot \cos \frac{\pi}{4} z^{-1} + \left(\frac{\sqrt{2}}{2}\right)^2 z^{-2}}$$

$$X(z) = \frac{16}{29} \frac{1}{1 + \frac{3}{4}z^{-1}} - \frac{16}{29} \frac{1 - \frac{1}{2}z^{-1}}{1 - 2 \cdot \frac{\sqrt{2}}{2} \cdot \cos \frac{\pi}{4} z^{-1} + \left(\frac{\sqrt{2}}{2}\right)^2 z^{-2}} + \frac{80}{58} \frac{\frac{1}{2}z^{-1}}{1 - 2 \cdot \frac{\sqrt{2}}{2} \cdot \cos \frac{\pi}{4} z^{-1} + \left(\frac{\sqrt{2}}{2}\right)^2 z^{-2}}$$

$$X(z) = \frac{16}{29} \frac{1}{1 + \frac{3}{4}z^{-1}} - \frac{16}{29} \frac{1 - \frac{\sqrt{2}}{2} \cdot \cos \frac{\pi}{4} z^{-1}}{1 - 2 \cdot \frac{\sqrt{2}}{2} \cdot \cos \frac{\pi}{4} z^{-1} + \left(\frac{\sqrt{2}}{2}\right)^2 z^{-2}} + \frac{80}{58} \frac{\frac{\sqrt{2}}{2} \cdot \sin \frac{\pi}{4} z^{-1}}{1 - 2 \cdot \frac{\sqrt{2}}{2} \cdot \cos \frac{\pi}{4} z^{-1} + \left(\frac{\sqrt{2}}{2}\right)^2 z^{-2}}$$

$$(r^n \cos w_0 n)u[n] \xleftrightarrow{z} \frac{1 - r \cos \frac{\pi}{4} z^{-1}}{1 - 2r \cos \frac{\pi}{4} z^{-1} + r^2 z^{-2}} \quad \text{for} \quad \text{ROC } |z| > r$$

$$(r^n \sin w_0 n)u[n] \xleftrightarrow{z} \frac{r \sin \frac{\pi}{4} z^{-1}}{1 - 2r \cos \frac{\pi}{4} z^{-1} + r^2 z^{-2}} \quad \text{for} \quad \text{ROC } |z| > r$$

$$x[n] = \frac{16}{29} \left(-\frac{3}{4}\right)^n u[n] - \frac{16}{29} (r^n \cos w_0 n)u[n] + \frac{80}{58} (r^n \sin w_0 n)u[n]$$